

INTERIOR ELEVATION

Scale: None

Door Curtain:
 .017 Hot Dip Galvanized Steel
 ASTM A-653 Structural Steel
 (Grade 80) With Full Coat Of Primer And
 Baked Polyester Finish Coat.

Steel Jamb mounting: maximum spacing of guide anchors "X" = 37.125".
 Masonry Jamb mounting: maximum spacing of guide anchors "X" = 40".

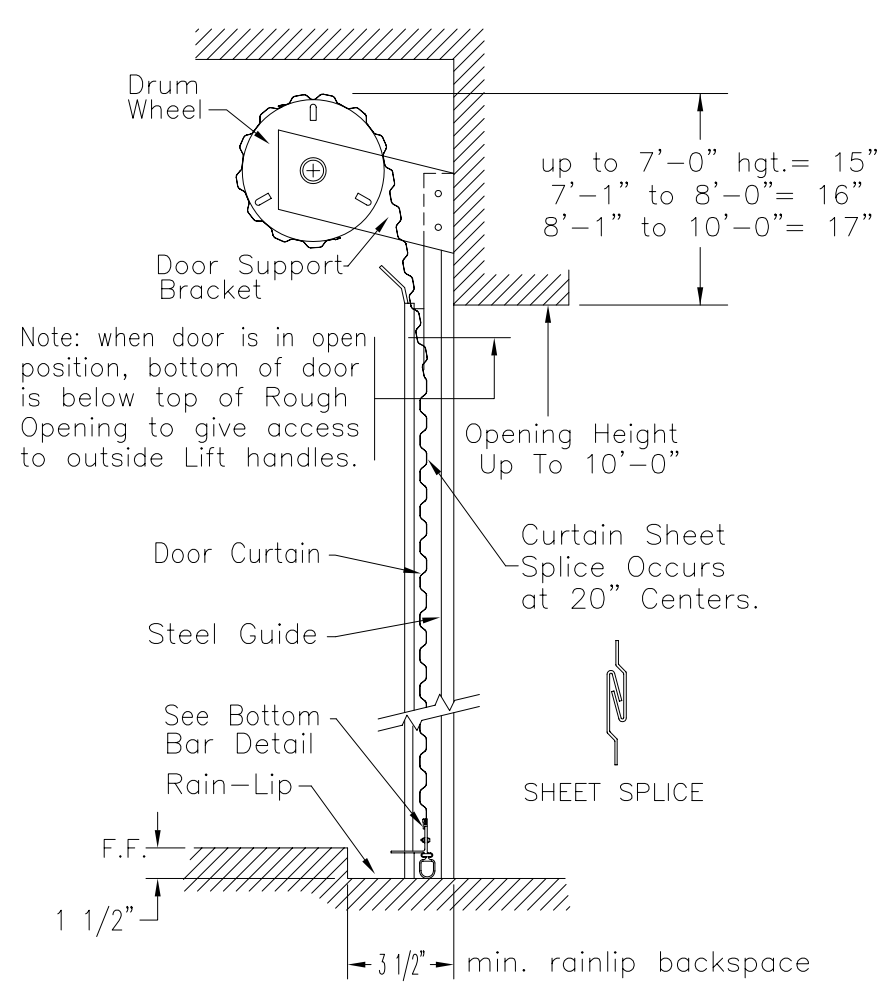

SECTION THRU DOOR

Scale: None

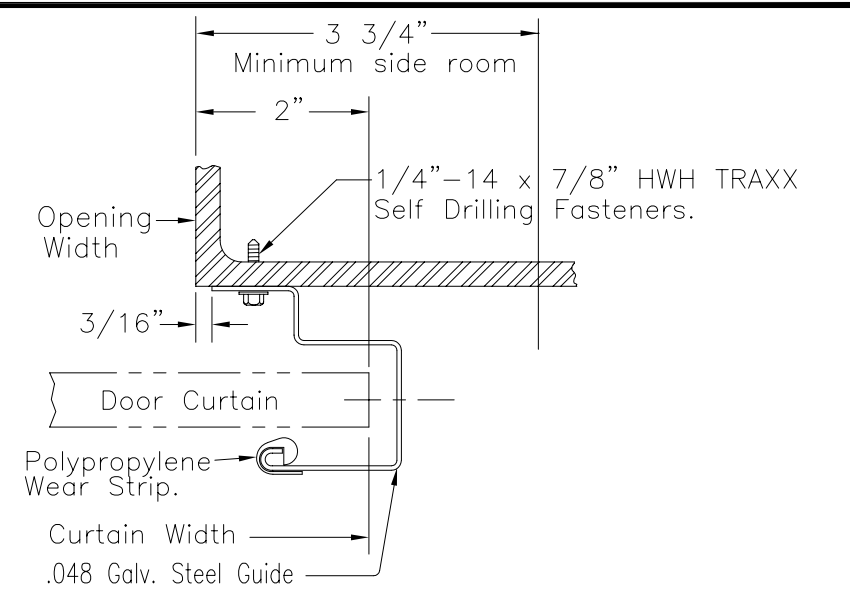

STEEL JAMBS

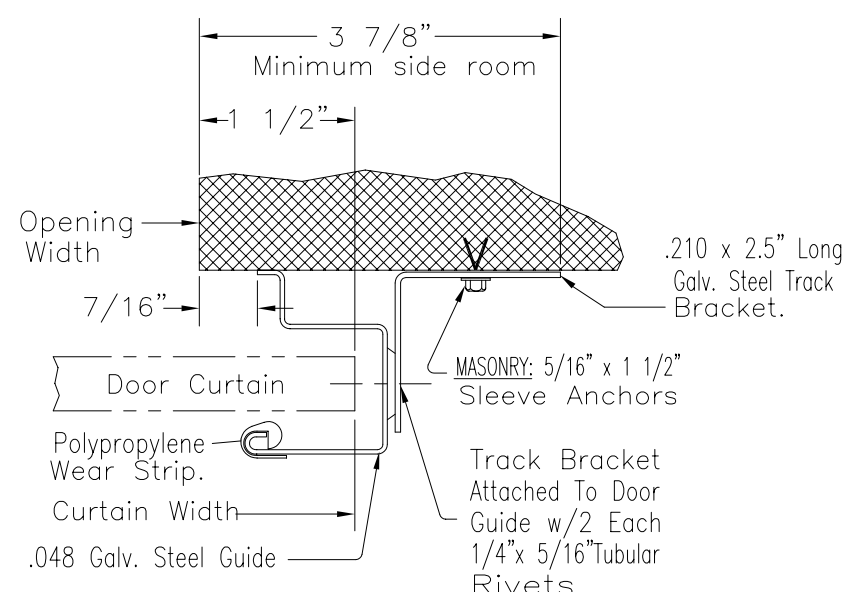

MASONRY JAMBS

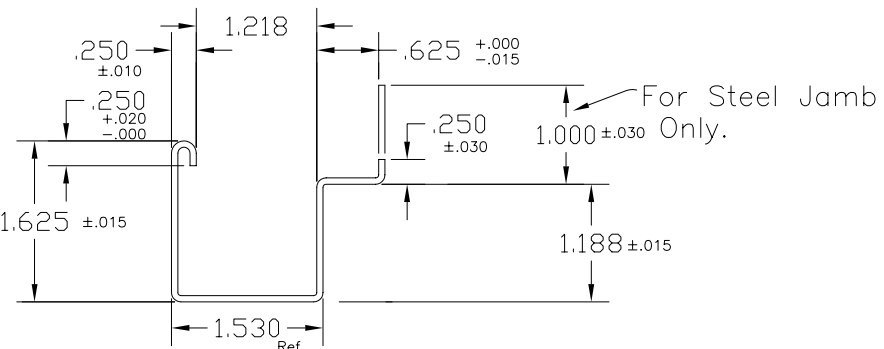

501 DOOR GUIDE

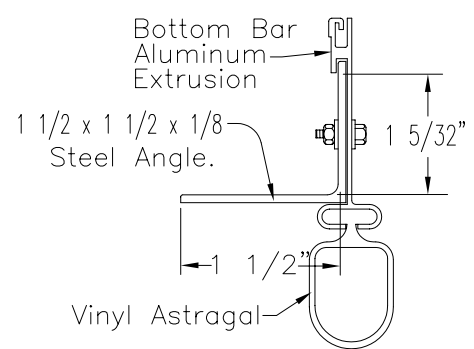

BOTTOM BAR

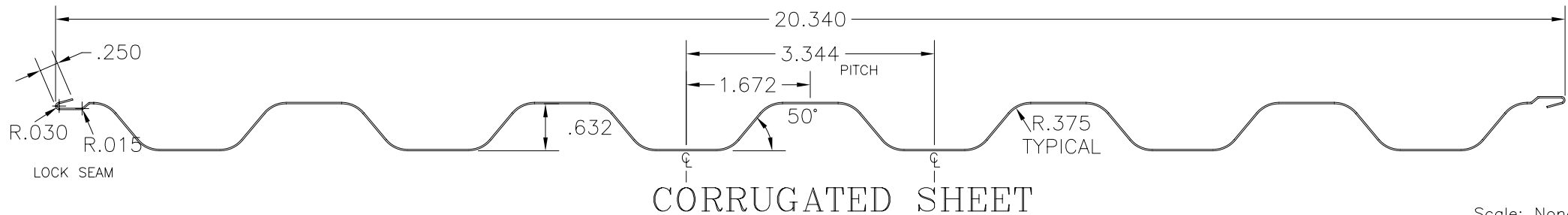

Scale: None

"D"					
"C"					
"B"					
"A"				MANUAL	
DOOR	QTY.	WIDTH	HGT.	TYPE OF OPERATION	SPECIAL COMMENTS

Maximum door size 10'-0" wide x 10'-0" high

MODEL 501

Trackomatic Inc.

DATE: 10-23-03 SHEET: 1
 DRAWN BY: C.D.W.
 CHECKED BY:
 DRAWING NUMBER

501-00-120

Oct. 23, 2003